

CONTINENTAL *Trailers*



TRAILER BROCHURE



Committed To Quality. Committed To You.

THE LEADER IN DESIGN INNOVATION AND MANUFACTURING

For over 40 years Continental Trailers has been a leader and innovator in the boat trailer industry. Since 1975, our trailers have been engineered and built to withstand the severe saltwater environment of Florida and the tropics. Even with years of experience behind us, we are continuously creating better designs and product improvements. Quality and dependability are key features of our trailers.

With state-of-the-art manufacturing facilities in Miami and St. Petersburg, Florida, we utilize more than 60,000 s.f. of building space. Our manufacturing equipment is the most current available and operated by trained experienced employees who are dedicated to producing top quality products. In order to ensure fast delivery, we have a fleet of 16 delivery trucks that cover Florida daily. So whether you own a 10' jet ski or a 45' powerboat. Continental Trailers has a model to fit your needs.



QUALITY AND DEPENDABILITY SINCE 1975

SELECTING THE RIGHT TRAILER

WEIGHT

The weight of your boat needs to include engine(s), fuel, gear and any factory added options that the builder did not include in its boat weight. This weight along with your expected trailer usage will determine the capacity of the trailer. Trailers are manufactured to carry a predetermined weight and should not be overloaded.

LENGTH

The Length of the is boat from the pulpit (if included) to the engine mount. Remember, if you are towing with a van or camper you don't want the pulpit over the coupler on the trailer.

TYPE

Many trailers are designed to allow the owner to carefully drive the boat on and off. However, some ramps are too shallow to allow adequate submersion for the boat to load properly. Other ramps may have a drop-off at the water's edge and will not allow proper launching. Be sure to determine if your trailer will perform adequately at your local marina.

FINISH

Aluminum or Galvanized. Galvanized trailers offer a protective coating that normally prevents rust for several years. Aluminum trailers will experience virtually no corrosion and are somewhat lighter in weight. Both perform well in salt water.

AXLES

Single or Multiple Axle trailers are available on all models 18' long and larger. Both models have advantages and disadvantages. Single axle trailers are lighter in weight and easier to maneuver however, their weight capacities are less. Models with multiple axles can carry more weight but are somewhat more difficult to back-up. If you plan to do a lot of long distance driving, consider choosing a multiple axle trailer for the safety it provides in case of a tire failure.

D.O.T.

Wide boats and trailers may be subject to certain state towing laws. Please check with your state D.O.T. for regulations.

LAWS

The State of Florida requires brakes on all axles of any trailer with a **G.V.W.R. of 3000 lbs. or more.** This means the combined weight of the boat, trailer and all equipment being towed. Most other states have similar laws.

When selecting a trailer for your needs, be sure you comply with these legal statutes. Additionally, today's lighter weight vehicles may not provide adequate braking by themselves.

Drive safely; make sure your trailer has brakes installed.

“A” MODELS ALUMINUM



A1820



A2685B

*TRAILER SHOWN WITH OPTIONS

NOTE: FLORIDA STATUTE 316.261 SEC. (3) SUB. SEC. (A) REQUIRES BRAKES ON ALL AXLES OF ANY TRAILER WITH A G.V.W.R. OF 3000 LBS OR MORE. ANY TRAILERS ORDERED THAT DO NOT COMPLY WITH FLORIDA LAW SHOULD NOT BE TOWED ON PUBLIC ROADS. THE TRAILER OWNER ACCEPTS ALL RESPONSIBILITY AND LIABILITY FOR USE OF THE TRAILER.

MODEL NO.	BOAT LENGTH	NO. OF AXLES	GROSS CAPACITY	NET LOAD CAPACITY	TIRE SIZE	FRAME WIDTH	TRAILER WIDTH
A1412*	12' - 14'	1	1550 LBS	1200 LBS	12B	48"	66"
A1415*	12' - 14'	1	1900 LBS	1500 LBS	12C	48"	66"
A1515*	14' - 15'	1	1900 LBS	1500 LBS	12C	59"	78"
A1617	15' - 16'	1	2200 LBS	1700 LBS	13C	66"	89"
A1620	15' - 16'	1	2500 LBS	2000 LBS	13C	72"	95"
A1630B	15' - 16'	1	3500 LBS	3000 LBS	14C	72"	95"
A1820	17' - 18'	1	2600 LBS	2000 LBS	13C	72"	95"
A1830B	17' - 18'	1	3500 LBS	2900 LBS	14C	72"	95"
A1836B	17' - 18'	1	4200 LBS	3600 LBS	15D	80"	104"
A1840B	17' - 18'	2	4700 LBS	4000 LBS	13C	72"	95"
A2030B	19' - 20'	1	3500 LBS	2900 LBS	14C	72"	95"
A2044B	19' - 20'	2	5200 LBS	4400 LBS	13C	72"	95"
A2130B	20' - 21'	1	3500 LBS	2900 LBS	14C	72"	95"
A2144B	20' - 21'	2	5300 LBS	4400 LBS	13C	72"	95"
A2150B	20' - 21'	2	6000 LBS	5000 LBS	14C	72"	95"
A2244B	21' - 22'	2	5300 LBS	4400 LBS	13C	80"	102"
A2250B	21' - 22'	2	6000 LBS	5000 LBS	14C	80"	102"
A2260B	21' - 22'	2	7000 LBS	5800 LBS	14C	80"	102"
A2450B	24' - 25'	2	6100 LBS	5000 LBS	14C	80"	102"
A2460B	24' - 25'	2	7000 LBS	5800 LBS	14C	80"	102"
A2485B	24' - 25'	2	10160 LBS	8500 LBS	15D	80"	104"
A2660B	26' - 27'	2	7000 LBS	5800 LBS	14C	80"	102"
A2685B	26' - 27'	2	9800 LBS	8500 LBS	15D	80"	104"
A2610B	26' - 27'	2	12000 LBS	10000 LBS	R16	80"	104"
A2885B	28' - 29'	2	10160 LBS	8500 LBS	15D	80"	104"
A2810B	28' - 29'	2	12000 LBS	10000 LBS	R16	80"	104"
A2812B	28' - 29'	2	15200 LBS	12000 LBS	R16	80"	104"
A2813B	28' - 29'	3	15200 LBS	13000 LBS	15D	80"	104"

STANDARD EQUIPMENT

- TORSION AXLES, STAINLESS HARDWARE AND LED LIGHTS ON ALL MODELS 3000 LBS AND LARGER
- BRAKES ON ALL AXLES WITH B SUFFIX
- ALUMINUM I-BEAM FRAME
- ALUMINUM VEE CROSS MEMBERS
- ALUMINUM DIAMOND PLATE FENDERS
- GALVANIZED AXLES, HUBS AND WHEELS
- ADJUSTABLE HULL SUPPORTS
- ADJUSTABLE BOW STOP AND WINCH STAND
- BEARING PROTECTION SYSTEM
- HEAVY DUTY WINCH
- TONGUE JACK
- ALUMINUM REAR VERTICAL LOADING GUIDES A1617 & LARGER
- FRONT CENTERING GUIDES ON MODEL A2030B AND LARGER
- *C-CHANNEL FRAME

OPTIONS AVAILABLE

- RADIAL TIRES
- SPARE TIRE AND WHEEL
- FRONT FLAT BUNK EXCHANGE
- ALUMINUM WHEELS

ALL TRAILER MODEL NUMBERS ENDING WITH "B" ARE ASSEMBLED WITH BRAKES ON ALL AXLES. THESE MODELS ARE AVAILABLE WITHOUT BRAKES; HOWEVER, THE LOAD CAPACITY IS GREATLY REDUCED TO COMPLY WITH FLORIDA LAW.

“CA” & “CTA” MODELS ALUMINUM

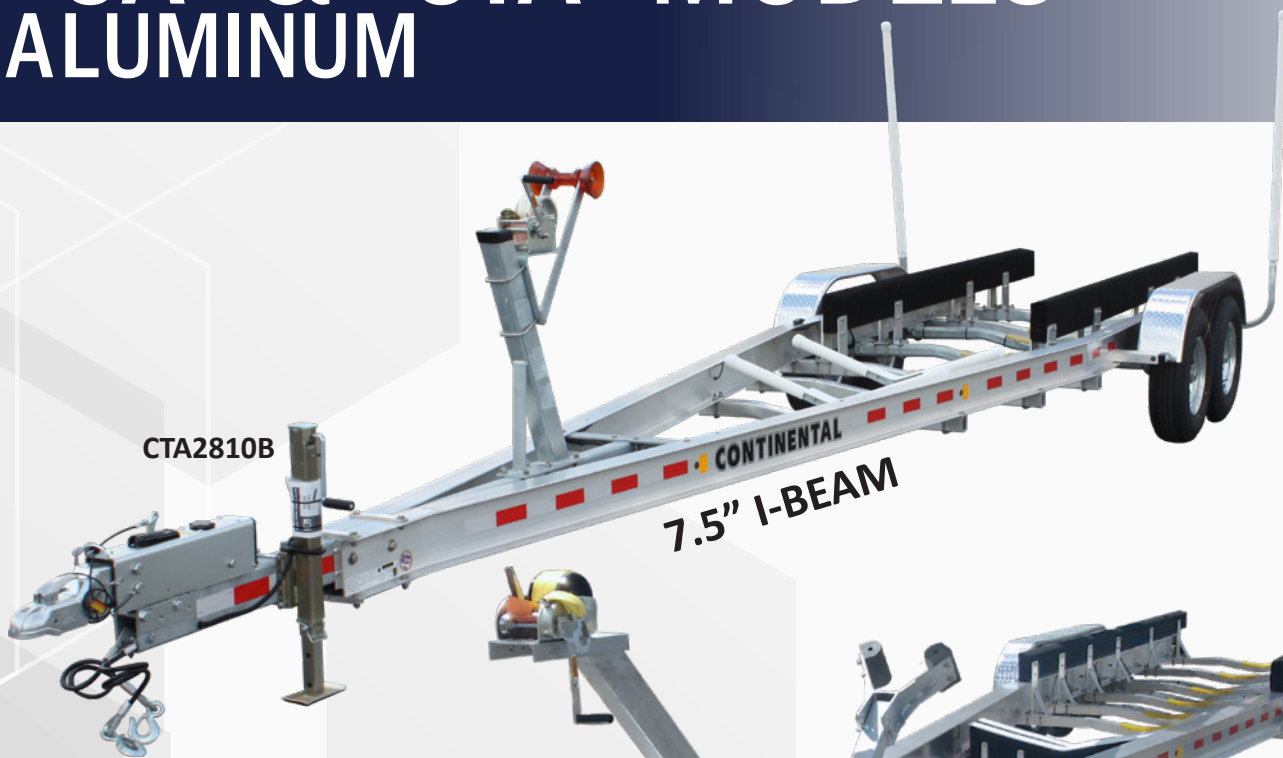

CTA2810B

7.5" I-BEAM



CTA4220B

10" I-BEAM

*TRAILER SHOWN WITH OPTIONS

SUPER DUTY TRAILER
23,760 LBS GROSS CAPACITY
20,000 LBS NET CAPACITY

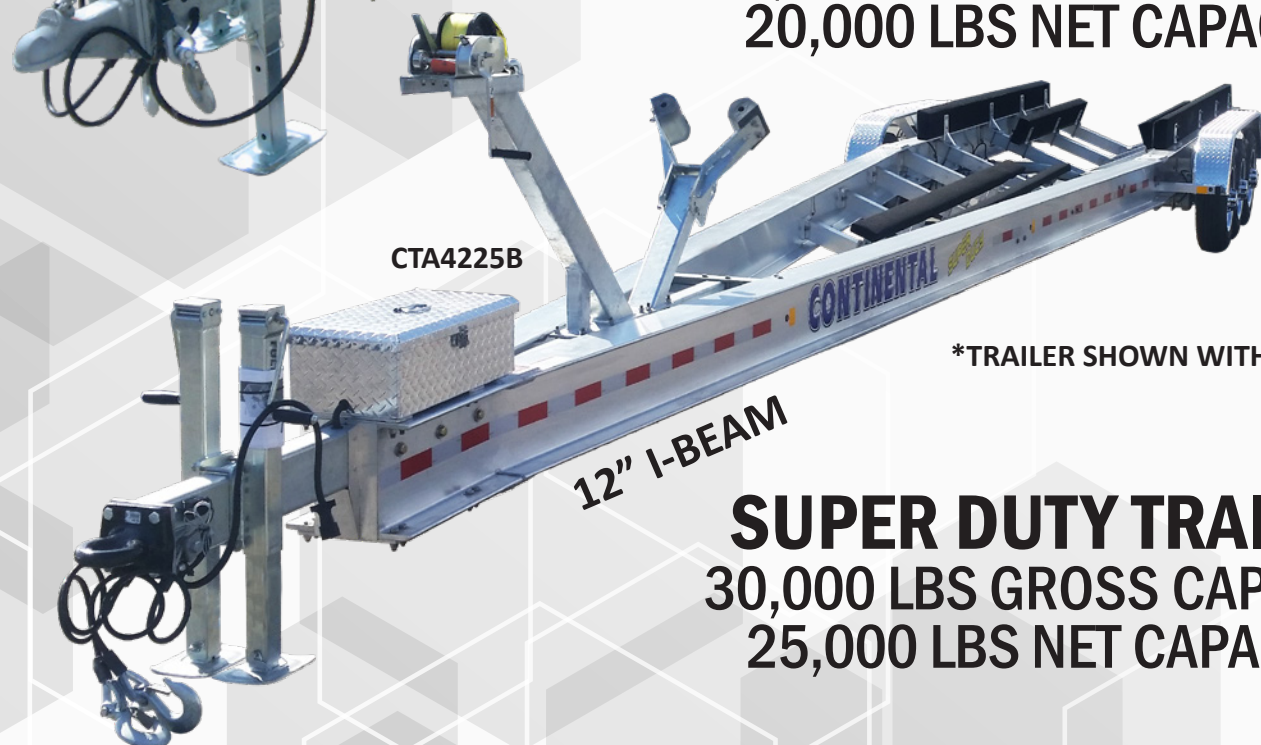

CTA4225B

12" I-BEAM

*TRAILER SHOWN WITH OPTIONS

SUPER DUTY TRAILER
30,000 LBS GROSS CAPACITY
25,000 LBS NET CAPACITY

NOTE: FLORIDA STATUTE 316.261 SEC. (3) SUB. SEC. (A) REQUIRES BRAKES ON ALL AXLES OF ANY TRAILER WITH A G.V.W.R. OF 3000 LBS OR MORE. ANY TRAILERS ORDERED THAT DO NOT COMPLY WITH FLORIDA LAW SHOULD NOT BE TOWED ON PUBLIC ROADS. THE TRAILER OWNER ACCEPTS ALL RESPONSIBILITY AND LIABILITY FOR USE OF THE TRAILER.

MODEL NO.	BOAT LENGTH	NO. OF AXLES	GROSS CAPACITY	NET LOAD CAPACITY	TIRE SIZE	FRAME WIDTH	TRAILER WIDTH
CA1830B	17' - 18'	1	3500 LBS	2860 LBS	14C	72"	95"
CA1840B	17' - 18'	2	5000 LBS	4220 LBS	13C	72"	95"
CA2030B	19' - 20'	1	3500 LBS	2820 LBS	14C	72"	95"
CTA2044B	19' - 20'	2	5200 LBS	4400 LBS	13C	72"	95"
CTA2144B	20' - 21'	2	5200 LBS	4400 LBS	13C	72"	95"
CTA2150B	20' - 21'	2	6000 LBS	5000 LBS	14C	72"	95"
CTA2350B	22' - 23'	2	6000 LBS	5000 LBS	14C	80"	102"
CTA2360B	22' - 23'	2	7040 LBS	5900 LBS	14C	80"	102"
CTA2560B	24' - 25'	2	7040 LBS	5800 LBS	14C	80"	102"
CTA2585B	24' - 25'	2	10160 LBS	8500 LBS	15D	80"	104"
CTA2785B	26' - 27'	2	10160 LBS	8500 LBS	15D	80"	104"
CTA2710B	26' - 27'	2	12000 LBS	10000 LBS	R16	80"	106"
CTA2885B	27' - 28'	2	10160 LBS	8500 LBS	15D	80"	104"
CTA2810B	27' - 28'	2	12000 LBS	10000 LBS	R16	80"	106"
CTA2813B	27' - 28'	3	15240 LBS	13000 LBS	15D	80"	104"
CTA3110B	29' - 31'	2	12000 LBS	10000 LBS	R16	80"	106"
CTA3112B	29' - 31'	2	14000 LBS	12000 LBS	R16	80"	104"
CTA3113B	29' - 31'	3	15240 LBS	13000 LBS	15D	80"	104"
CTA3115B	29' - 31'	3	17700 LBS	15000 LBS	R16	80"	106"
CTA3513B	32' - 35'	3	15240 LBS	13000 LBS	15D	80"	104"
CTA3515B	32' - 35'	3	17700 LBS	15000 LBS	R16	80"	106"
CTA3517B	32' - 35'	3	19700 LBS	17000 LBS	R16	80"	106"
CTA3520B	32' - 35'	3	23760 LBS	20000 LBS	R16	80"	106"
CTA4015B	36' - 40'	3	17700 LBS	15000 LBS	R16	80"	106"
CTA4017B	36' - 40'	3	19700 LBS	17000 LBS	R16	80"	106"
CTA4020B	36' - 40'	3	23760 LBS	20000 LBS	R16	80"	106"
CTA4220B	40' - 42'	3	23760 LBS	20000 LBS	R16	80"	106"
CTA4225B	40' - 42'	3	30000 LBS	25000 LBS	R17.5	78"	104"

STANDARD EQUIPMENT

- TORSION AXLES, STAINLESS HARDWARE AND LED LIGHTS ON ALL MODELS 3000 LBS AND LARGER
- BRAKES ON ALL AXLES
- ALUMINUM I-BEAM FRAME
- ALUMINUM VEE CROSS MEMBERS
- ALUMINUM DIAMOND PLATE FENDERS
- ADJUSTABLE HULL SUPPORTS
- GALVANIZED AXLES, HUBS AND WHEELS
- BEARING PROTECTION SYSTEM
- POLYURETHANE ROLLERS AND KEEL PROTECTION PADS
- TONGUE JACK AND WINCH
- REAR VERTICAL LOADING GUIDES ON CA18 - CTA31
- FRONT CENTERING GUIDES ON MODEL CA2030B AND LARGER
- FRONT BUNKS ON 17,000 LB AND LARGER

OPTIONS AVAILABLE

- RADIAL TIRES
- FRONT FLAT BUNK EXCHANGE
- SPARE TIRE AND WHEEL
- ALUMINUM WHEELS
- ELECTRIC OVER HYDRAULIC BRAKING SYSTEM

ALL TRAILER MODEL NUMBERS ENDING WITH "B" ARE ASSEMBLED WITH BRAKES ON ALL AXLES. THESE MODELS ARE AVAILABLE WITHOUT BRAKES; HOWEVER, THE LOAD CAPACITY IS GREATLY REDUCED TO COMPLY WITH FLORIDA LAW.

SKIFF MODELS

ALUMINUM

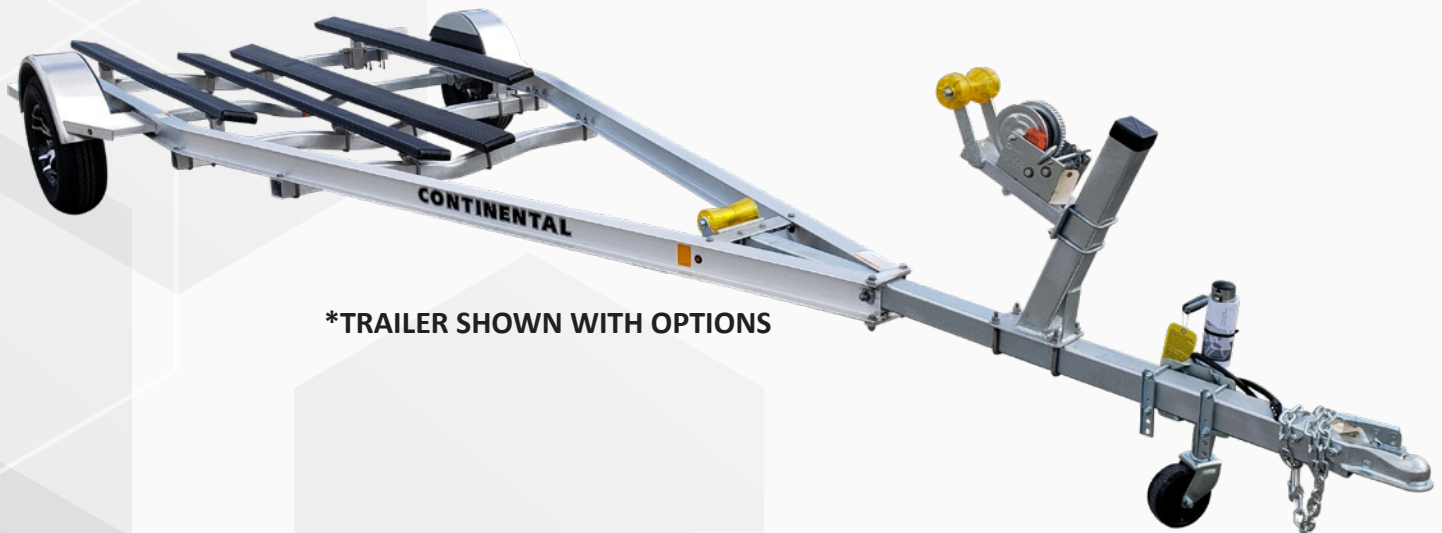

*TRAILER SHOWN WITH OPTIONS

AS1830

ALUMINUM SKIFF TRAILERS

MODEL NO.	BOAT LENGTH	NO. OF AXLES	GROSS CAPACITY	NET LOAD CAPACITY	TIRE SIZE	FRAME WIDTH	TRAILER WIDTH
AS1616*	14' - 16'	1	2100 LBS	1600 LBS	13C	60"	80"
AS1620	15' - 16'	1	2600 LBS	2000 LBS	13C	80"	102"
AS1630B	15' - 16'	1	3500 LBS	3000 LBS	14C	80"	102"
AS1820	17' - 18'	1	2600 LBS	2000 LBS	13C	80"	102"
AS1830B	17' - 18'	1	3500 LBS	2900 LBS	14C	80"	102"
AS2030B	19' - 20'	1	3500 LBS	2900 LBS	14C	80"	102"
AS2044B	19' - 20'	2	5200 LBS	4400 LBS	13C	80"	102"
AS2130B	20' - 21'	1	3500 LBS	2900 LBS	14C	80"	102"
AS2144B	20' - 21'	2	5200 LBS	4400 LBS	13C	80"	102"

STANDARD EQUIPMENT

- TORSION AXLES, STAINLESS HARDWARE AND LED LIGHTS ON ALL MODELS 3000 LBS AND LARGER
- BRAKES ON ALL AXLES OF TRAILER MODELS ENDING IN "B"
- ALUMINUM I-BEAM FRAME
- ALUMINUM VEE CROSS MEMBERS
- PLASTIC FENDERS WITH BACK AND STEP ON TRAILERS UP TO 3000 LBS
- ALUMINUM FENDERS ON MODELS OVER 3000 LBS
- CARPETED HULL SUPPORTS
- GALVANIZED AXLES, HUBS AND WHEELS
- REAR VERTICAL LOADING GUIDES
- TONGUE JACK
- *AS1616 MODEL COMES WITH ALUMINUM CHANNEL FRAME, TORSION AXLE, AND LED LIGHTS

OPTIONS AVAILABLE

- SPARE TIRE AND WHEEL
- RADIAL TIRES
- ALUMINUM WHEELS

NOTE: FLORIDA STATUTE 316.261 SEC. (3) SUB. SEC. (A) REQUIRES BRAKES ON ALL AXLES OF ANY TRAILER WITH A G.V.W.R. OF 3000 LBS OR MORE. ANY TRAILERS ORDERED THAT DO NOT COMPLY WITH FLORIDA LAW SHOULD NOT BE TOWED ON PUBLIC ROADS. THE TRAILER OWNER ACCEPTS ALL RESPONSIBILITY AND LIABILITY FOR USE OF THE TRAILER.

“CAT” MODELS ALUMINUM



*TRAILER SHOWN WITH OPTIONS

CATAMARAN TRAILERS

MODEL NO.	BOAT LENGTH	NO. OF AXLES	GROSS CAPACITY	NET LOAD CAPACITY	TIRE SIZE	FRAME WIDTH	TRAILER WIDTH
CAT1830B	17'-18'	1	3500 LBS	2700 LBS	14C	80"	102"
CAT2144B	20'-21'	2	5200 LBS	4400 LBS	13C	80"	102"
CAT2150B	20'-21'	2	6000 LBS	5000 LBS	14C	80"	102"
CAT2360B	22'-23'	2	7000 LBS	5900 LBS	14C	80"	102"
CAT2382B	22'-23'	2	10000 LBS	8200 LBS	15D	80"	102"
CAT2560B	24'-25'	2	7000 LBS	5900 LBS	14C	80"	102"
CAT2582B	24'-25'	2	10000 LBS	8200 LBS	15D	80"	102"
CAT2782B	26'-27'	2	10000 LBS	8200 LBS	15D	80"	104"
CAT2913B	27'-29'	3	15000 LBS	13000 LBS	15D	80"	104"
CAT3115B	29'-31'	3	17000 LBS	15000 LBS	R16	80"	106"

STANDARD EQUIPMENT

- TORSION AXLES, STAINLESS HARDWARE AND LED LIGHTS
- BRAKES ON ALL AXLES OF TRAILER MODELS ENDING IN “B”
- ALUMINUM I-BEAM FRAME
- ALUMINUM CROSS MEMBERS
- ALUMINUM DIAMOND PLATE FENDERS
- GALVANIZED AXLES, HUBS AND WHEELS
- BEARING PROTECTION SYSTEM
- TONGUE JACK AND WINCH

OPTIONS AVAILABLE

- ALUMINUM WHEELS
- RADIAL TIRES
- SPARE TIRE AND WHEEL
- BOARDING LADDER

ALL TRAILER MODEL NUMBERS ENDING WITH “B” ARE ASSEMBLED WITH BRAKES ON ALL AXLES. THESE MODELS ARE AVAILABLE WITHOUT BRAKES; HOWEVER, THE LOAD CAPACITY IS GREATLY REDUCED TO COMPLY WITH FLORIDA LAW.

PONTOON MODELS

ALUMINUM



ACP2024

*TRAILER SHOWN WITH OPTIONS

ALUMINUM PONTOON TRAILERS

MODEL NO.	BOAT LENGTH	NO. OF AXLES	GROSS CAPACITY	NET LOAD CAPACITY	TIRE SIZE	FRAME WIDTH	TRAILER WIDTH
ACP1620	15' - 17'	1	2500 LBS	2000 LBS	10D	76"	96"
ACP2024	16' - 20'	1	2999 LBS	2400 LBS	10E	76"	96"
ACTP2035B	16' - 20'	2	4200 LBS	3500 LBS	13C	80"	102"
ACTP2444B	20' - 24'	2	4400 LBS	3500 LBS	13C	80"	102"
ACTP2450B	20' - 24'	2	6000 LBS	5000 LBS	14C	80"	102"
ACTP2838B	25' - 28'	2	5100 LBS	3800 LBS	13C	80"	102"
ACTP2848B	25' - 28'	2	6100 LBS	4800 LBS	14C	80"	102"
ACTP2870B	25' - 28'	3	9900 LBS	7000 LBS	14C	80"	102"

STANDARD EQUIPMENT

- TORSION AXLES, STAINLESS HARDWARE AND LED LIGHTS ON ALL MODELS 3000 LBS AND LARGER
- BRAKES ON ALL MODELS ENDING IN "B"
- ALUMINUM FRAME AND CROSS MEMBERS
- GALVANIZED AXLES, HUBS AND WHEELS
- ADJUSTABLE WINCH STAND AND BOW STOP
- BEARING LUBRICATION SYSTEM
- HEAVY DUTY WINCH WITH STRAP
- TONGUE JACK
- COMPOSITE BUNK COVERS

OPTIONS AVAILABLE

- SPARE TIRE AND WHEEL
- PVC PONTOON GUIDES
- DELUXE STEP LADDER
- TRI-TOON OPTION

NOTE: FLORIDA STATUTE 316.261 SEC. (3) SUB. SEC. (A) REQUIRES BRAKES ON ALL AXLES OF ANY TRAILER WITH A G.V.W.R. OF 3000 LBS OR MORE. ANY TRAILERS ORDERED THAT DO NOT COMPLY WITH FLORIDA LAW SHOULD NOT BE TOWED ON PUBLIC ROADS. THE TRAILER OWNER ACCEPTS ALL RESPONSIBILITY AND LIABILITY FOR USE OF THE TRAILER.

PONTOON MODELS GALVANIZED

STANDARD EQUIPMENT

- BRAKES ON ALL AXLES OF TRAILER
- MODELS ENDING IN "B"
- GALVANIZED FRAME, AXLES AND WHEELS
- ADJUSTABLE WINCH STAND AND BOW STOP
- BEARING LUBRICATION SYSTEM
- HEAVY DUTY WINCH WITH STRAP
- TONGUE JACK
- COMPOSITE BUNK COVERS

OPTIONS AVAILABLE

- SPARE TIRE AND WHEEL
- PVC PONTOON GUIDES
- DELUXE STEP LADDER
- TRI-TOON OPTION



*TRAILER SHOWN WITH OPTIONS

CP2024

GALVANIZED PONTOON TRAILERS

MODEL NO.	BOAT LENGTH	NO. OF AXLES	GROSS CAPACITY	NET LOAD CAPACITY	TIRE SIZE	FRAME WIDTH	TRAILER WIDTH
CP1616	14' - 16'	1	2090 LBS	1600 LBS	12C	76"	96"
CP2016	16' - 20'	1	2200 LBS	1650 LBS	10C	76"	96"
CP2024	16' - 20'	1	2999 LBS	2400 LBS	10E	76"	96"
CTP2030B	16' - 20'	2	3500 LBS	2900 LBS	13C	76"	96"
CTP2040B	16' - 20'	2	4800 LBS	4000 LBS	13C	76"	96"
CTP2435B	20' - 24'	2	4400 LBS	3500 LBS	13C	76"	96"
CTP2444B	20' - 24'	2	5300 LBS	4400 LBS	13C	76"	96"
CTP2455B	20' - 24'	2	6500 LBS	5500 LBS	14C	76"	96"
CTP2848B	25' - 28'	2	6100 LBS	4800 LBS	14C	76"	96"
CTP2855B	25' - 28'	2	6600 LBS	5500 LBS	14C	76"	96"
CTP2860B	25' - 28'	3	7400 LBS	6000 LBS	13C	76"	96"
CTP3170B	28' - 31'	3	8600 LBS	7000 LBS	14C	76"	96"

ALL TRAILER MODEL NUMBERS ENDING WITH "B" ARE ASSEMBLED WITH BRAKES ON ALL AXLES. THESE MODELS ARE AVAILABLE WITHOUT BRAKES; HOWEVER, THE LOAD CAPACITY IS GREATLY REDUCED TO COMPLY WITH FLORIDA LAW.

BLAZER MODELS GALVANIZED



GALVANIZED BLAZER TRAILERS

MODEL NO.	BOAT LENGTH	NO. OF AXLES	GROSS CAPACITY	NET LOAD CAPACITY	TIRE SIZE	FRAME WIDTH	TRAILER WIDTH
BLAZER 1720	16' - 17'	1	2600 LBS	2000 LBS	13C	72"	96"
BLAZER 1728B	16' - 17'	1	3400 LBS	2800 LBS	14C	72"	96"
BLAZER 1928B	18' - 19'	1	3400 LBS	2800 LBS	14C	72"	96"
BLAZER 1936B	18' - 19'	1	4200 LBS	3600 LBS	15D	72"	96"
BLAZER 1944B	18' - 19'	2	5200 LBS	4400 LBS	13C	72"	96"
BLAZER 2128B	20' - 21'	1	3400 LBS	2800 LBS	14C	72"	96"
BLAZER 2136B	20' - 21'	1	4200 LBS	3600 LBS	15D	72"	96"
BLAZER 2144B	20' - 21'	2	5200 LBS	4400 LBS	13C	72"	96"
BLAZER 2358B	22' - 23'	2	7000 LBS	5800 LBS	14C	72"	96"
BLAZER 2558B	24' - 26'	2	7000 LBS	5800 LBS	14C	72"	96"
BLAZER 2575B	24' - 26'	2	9000 LBS	7500 LBS	15D	72"	96"

STANDARD EQUIPMENT

- BRAKES ON ALL AXLES OF TRAILER MODELS ENDING IN "B"
- GALVANIZED FRAME, AXLES, HUBS AND WHEELS
- ADJUSTABLE HULL SUPPORTS
- KEEL PROTECTION PADS
- VERTICAL LOADING GUIDES
- ADJUSTABLE WINCH STAND AND BOW STOP
- HEAVY DUTY WINCH WITH STRAP
- BEARING LUBRICATION SYSTEM
- TONGUE JACK
- WATERPROOF LIGHTS
- FRONT CENTERING GUIDES ON 23' & 25' MODELS

OPTIONS AVAILABLE

- SPARE TIRE AND WHEEL
- RADIAL TIRES

NOTE: FLORIDA STATUTE 316.261 SEC. (3) SUB. SEC. (A) REQUIRES BRAKES ON ALL AXLES OF ANY TRAILER WITH A G.V.W.R. OF 3000 LBS OR MORE. ANY TRAILERS ORDERED THAT DO NOT COMPLY WITH FLORIDA LAW SHOULD NOT BE TOWED ON PUBLIC ROADS. THE TRAILER OWNER ACCEPTS ALL RESPONSIBILITY AND LIABILITY FOR USE OF THE TRAILER.

SMALL MODELS GALVANIZED



GALVANIZED KEEL ROLLER TRAILERS

MODEL NO.	BOAT LENGTH	NO. OF AXLES	GROSS CAPACITY	NET LOAD CAPACITY	TIRE SIZE	FRAME WIDTH	TRAILER WIDTH
EC29	10' - 12'	1	1150 LBS	900 LBS	8B	40"	56"
EC212	10' - 12'	1	1450 LBS	1200 LBS	12B	40"	56"
EC39	12' - 14'	1	1150 LBS	900 LBS	8B	40"	56"
EC312	12' - 14'	1	1450 LBS	1200 LBS	12B	40"	56"
EC312V	12' - 14'	1	1450 LBS	1200 LBS	12B	40"	56"
EW1312V	11' - 13'	1	1560 LBS	1200 LBS	12B	48"	66"

STANDARD EQUIPMENT

- GALVANIZED FRAME, AXLES AND WHEELS
- WATERPROOF LIGHTS
- ADJUSTABLE WINCH STAND AND BOW STOP
- WINCH WITH STRAP
- CARPETED BUNKS
- BEARING PROTECTORS
- JACK ON EW1312V

OPTIONS AVAILABLE

- TONGUE JACK ON EC MODELS
- SPARE TIRE AND WHEEL

ALL TRAILER MODEL NUMBERS ENDING WITH "B" ARE ASSEMBLED WITH BRAKES ON ALL AXLES. THESE MODELS ARE AVAILABLE WITHOUT BRAKES; HOWEVER, THE LOAD CAPACITY IS GREATLY REDUCED TO COMPLY WITH FLORIDA LAW.

TILT & UTILITY MODELS GALVANIZED



OPTIONS AVAILABLE

- SPARE TIRE AND WHEEL
- BEARING PROTECTORS
- POLY ROLLERS

GALVANIZED TILT TRAILERS

MODEL NO.	BOAT LENGTH	NO. OF AXLES	GROSS CAPACITY	NET LOAD CAPACITY	TIRE SIZE	FRAME WIDTH	TRAILER WIDTH
C412	12' - 14'	1	1550 LBS	1200 LBS	12B	56"	72"
C512	14' - 15'	1	1550 LBS	1200 LBS	12B	48"	66"
C515	14' - 15'	1	1900 LBS	1500 LBS	12C	48"	66"
C715	16' - 17'	1	1950 LBS	1500 LBS	12C	59"	78"
C717	16' - 17'	1	2200 LBS	1700 LBS	13C	59"	78"
CV720	16' - 17'	1	2600 LBS	2000 LBS	13C	59"	78"

STANDARD EQUIPMENT

- GALVANIZED FRAME, AXLES AND WHEELS
- WATERPROOF LIGHTS
- ADJUSTABLE WINCH STAND AND BOW STOP
- WINCH WITH STRAP
- FLAT BUNKS ON ALL MODELS
- TONGUE JACK



UTILITY TRAILERS

MODEL NO.	BED SIZE	GROSS CAPACITY	NET LOAD CAPACITY	TIRE SIZE	TRAILER WIDTH
UT4812	50" X 8'	1700 LBS	1200 LBS	12B	70"
UT5820	63" X 8'	2600 LBS	2000 LBS	13C	82"
UT5828B	63" X 8'	3500 LBS	2800 LBS	14C	82"
UT51028B	63" X 10'	3500 LBS	2800 LBS	14C	82"
UT61228B	75" X 12'	3500 LBS	2800 LBS	14C	104"

STANDARD EQUIPMENT

- GALVANIZED FRAME, AXLE AND WHEELS
- COMPLETE LIGHTS AND WIRING
- P.T. WOOD DECK FLOOR
- TONGUE JACK ON MODEL UT5820 AND LARGER

OPTIONS AVAILABLE

- SPARE TIRE AND WHEEL
- BEARING PROTECTION
- TAILGATE/RAMP

NOTE: FLORIDA STATUTE 316.261 SEC. (3) SUB. SEC. (A) REQUIRES BRAKES ON ALL AXLES OF ANY TRAILER WITH A G.V.W.R. OF 3000 LBS OR MORE. ANY TRAILERS ORDERED THAT DO NOT COMPLY WITH FLORIDA LAW SHOULD NOT BE TOWED ON PUBLIC ROADS. THE TRAILER OWNER ACCEPTS ALL RESPONSIBILITY AND LIABILITY FOR USE OF THE TRAILER.

BASS & SKIFF MODELS GALVANIZED



JB1612

OPTIONS AVAILABLE

- SPARE TIRE AND WHEEL
- TONGUE JACK
- BOAT GUIDES
- BEARING PROTECTORS

BASS BOAT/JON BOAT TRAILERS

MODEL NO.	BOAT LENGTH	NO. OF AXLES	GROSS CAPACITY	NET LOAD CAPACITY	TIRE SIZE	FRAME WIDTH	TRAILER WIDTH
JB127	10' - 12'	1	900 LBS	700 LBS	8B	40"	58"
JB157	13' - 15'	1	1000 LBS	700 LBS	8B	40"	58"
JB1512	13' - 15'	1	1500 LBS	1200 LBS	12B	40"	58"
JB1612	15' - 16'	1	1550 LBS	1200 LBS	12B	48"	64"
JB1812	17' - 18'	1	1550 LBS	1200 LBS	12B	64"	82"
CB1717	15' - 17'	1	2200 LBS	1700 LBS	13C	56"	76"

STANDARD EQUIPMENT

- GALVANIZED STEEL FRAME, AXLE AND WHEELS
- WATERPROOF LIGHTS
- WINCH WITH STRAP
- GALVANIZED U-BOLTS
- CARPETED FLAT BUNKS



CS1717

GALVANIZED SKIFF TRAILERS

MODEL NO.	BOAT LENGTH	NO. OF AXLES	GROSS CAPACITY	NET LOAD CAPACITY	TIRE SIZE	FRAME WIDTH	TRAILER WIDTH
CS1512	14' - 16'	1	1550 LBS	1200 LBS	12B	56"	72"
CS1715	16' - 17'	1	1950 LBS	1500 LBS	12C	66"	84"
CS1717	16' - 17'	1	2300 LBS	1700 LBS	13C	66"	86"
CS1916	18' - 19'	1	2300 LBS	1600 LBS	13C	66"	86"
CS2128B	20' - 21'	1	3500 LBS	2800 LBS	14C	76"	98"
CS2425B	22' - 24'	1	3500 LBS	2800 LBS	14C	76"	98"
CS2440B	22' - 24'	2	4800 LBS	4000 LBS	13C	76"	98"

STANDARD EQUIPMENT

- BRAKES ON ALL AXLES OF TRAILER MODELS ENDING IN "B"
- GALVANIZED FRAME, AXLES AND WHEELS
- ADJUSTABLE WINCH STAND AND BOW STOP
- FLAT BUNK HULL SUPPORT (NO ROLLERS)
- BEARING LUBRICATION SYSTEM
- LOADING GUIDES

OPTIONS AVAILABLE

- SPARE TIRE AND WHEEL
- TONGUE JACK
- WINCH WITH STRAP
- WATERPROOF LIGHTS

ALL TRAILER MODEL NUMBERS ENDING WITH "B" ARE ASSEMBLED WITH BRAKES ON ALL AXLES. THESE MODELS ARE AVAILABLE WITHOUT BRAKES; HOWEVER, THE LOAD CAPACITY IS GREATLY REDUCED TO COMPLY WITH FLORIDA LAW.

WATERCRAFT MODELS

ALUMINUM



AWC11E

SINGLE PERSONAL WATER CRAFT TRAILERS

MODEL NO.	GROSS CAPACITY	NET LOAD CAPACITY	TIRE SIZE	FRAME WIDTH	TRAILER WIDTH
AWC11E	1450 LBS	1100 LBS	12B	40"	56"
AWC412	1550 LBS	1200 LBS	12B	44"	60"
A1412	1560 LBS	1200 LBS	12B	48"	66"



AWC25E

DOUBLE PERSONAL WATER CRAFT TRAILERS

MODEL NO.	GROSS CAPACITY	NET LOAD CAPACITY	TIRE SIZE	FRAME WIDTH	TRAILER WIDTH
AWC20E	2499 LBS	2000 LBS	10D	82"	102"
AWC25E	2999 LBS	2500 LBS	10E	82"	102"
AWC825E	2999 LBS	2500 LBS	10E	82"	102"

STANDARD EQUIPMENT

- GALVANIZED OR ALUMINUM FRAME
- GALVANIZED AXLE AND WHEELS
- ADJUSTABLE WINCH-STAND AND BOW STOP
- ADJUSTABLE HULL SUPPORTS
- WINCH WITH STRAP
- WATERPROOF LIGHTS
- BEARING PROTECTION
- TONGUE JACK

OPTIONS AVAILABLE

- SPARE TIRE AND WHEEL

NOTE: FLORIDA STATUTE 316.261 SEC. (3) SUB. SEC. (A) REQUIRES BRAKES ON ALL AXLES OF ANY TRAILER WITH A G.V.W.R. OF 3000 LBS OR MORE. ANY TRAILERS ORDERED THAT DO NOT COMPLY WITH FLORIDA LAW SHOULD NOT BE TOWED ON PUBLIC ROADS. THE TRAILER OWNER ACCEPTS ALL RESPONSIBILITY AND LIABILITY FOR USE OF THE TRAILER.

WATERCRAFT MODELS GALVANIZED



WC3E12

SINGLE PERSONAL WATER CRAFT TRAILERS

MODEL NO.	GROSS CAPACITY	NET LOAD CAPACITY	TIRE SIZE	FRAME WIDTH	TRAILER WIDTH
WC2E9	1150 LBS	900 LBS	8B	40"	56"
WC2E12	1450 LBS	1200 LBS	12B	40"	56"
WC3E9	1170 LBS	900 LBS	8B	40"	56"
WC3E12	1500 LBS	1200 LBS	12B	40"	56"
WC412	1500 LBS	1200 LBS	12B	44"	60"
EW13V	1560 LBS	1200 LBS	12B	48"	66"



WC8E25

DOUBLE PERSONAL WATER CRAFT TRAILERS

MODEL NO.	GROSS CAPACITY	NET LOAD CAPACITY	TIRE SIZE	FRAME WIDTH	TRAILER WIDTH
WC6E1500	1980 LBS	1500 LBS	12C	80"	100"
WC7E20	2500 LBS	2000 LBS	10D	82"	102"
WC7E25	2999 LBS	2500 LBS	10E	82"	102"
WC8E25	2999 LBS	2500 LBS	10E	82"	102"

STANDARD EQUIPMENT

- GALVANIZED FRAME
- GALVANIZED AXLE AND WHEELS
- ADJUSTABLE WINCH-STAND AND BOW STOP
- ADJUSTABLE HULL SUPPORTS
- WINCH WITH STRAP
- WATERPROOF LIGHTS
- BEARING PROTECTION

OPTIONS AVAILABLE

- SPARE TIRE AND WHEEL

ALL TRAILER MODEL NUMBERS ENDING WITH "B" ARE ASSEMBLED WITH BRAKES ON ALL AXLES. THESE MODELS ARE AVAILABLE WITHOUT BRAKES; HOWEVER, THE LOAD CAPACITY IS GREATLY REDUCED TO COMPLY WITH FLORIDA LAW.

CANOE & KAYAK MODELS GALVANIZED



GALVANIZED CANOE/KAYAK TRAILERS

MODEL NO.	NO. OF CANOE/KAYAKS SUPPORTED	GROSS CAPACITY	NET LOAD CAPACITY	TIRE SIZE	TRAILER WIDTH
EC2K9	1 - 2	1170 LBS	900 LBS	8B	72"
EC2K12	1 - 2	1550 LBS	1200 LBS	12B	72"
KT412	4	1550 LBS	1200 LBS	12B	85"
KT4815	4	1980 LBS	1500 LBS	12C	50" x 8' BED
GT1612	1 GHEENOE	1550 LBS	1200 LBS	12B	60"

CANOE & KAYAK MODELS ALUMINUM



*TRAILER SHOWN WITH OPTIONS

AKT1412

ALUMINUM CANOE/KAYAK TRAILERS

MODEL NO.	NO. OF CANOE/KAYAKS SUPPORTED	GROSS CAPACITY	NET LOAD CAPACITY	TIRE SIZE	TRAILER WIDTH
AKT212	1 - 2	1550 LBS	1200 LBS	12B	85"
AKT412	4	1550 LBS	1200 LBS	12B	85"
GTA1612	1 GHEENOE	1550 LBS	1200 LBS	12B	64"

STANDARD EQUIPMENT

- GALVANIZED OR ALUMINUM FRAME AND UPRIGHTS
- GALVANIZED AXLE AND WHEELS
- TONGUE JACK ON KT412 AND KT4815 AND ALL ALUMINUM MODELS

OPTIONS AVAILABLE

- SPARE TIRE AND WHEEL
- TONGUE JACK ON EC2K



TWO YEAR LIMITED WARRANTY

WATERLAND MANUFACTURING OFFERS A LIMITED TWO YEAR WARRANTY ON ALL CONTINENTAL TRAILERS. SEE YOUR DEALER OR CALL US FOR A COPY OF OUR WARRANTY COVERAGE.

CONTINENTAL *Trailers*



AUTHORIZED DEALER



MIAMI

9200 N.W. 58TH STREET
DORAL, FL 33178

P: 305-594-1022
TOLL FREE: 800-432-1731
SALES@CONTINENTALTRAILERS.COM

ST. PETERSBURG

4033 35TH STREET NORTH
ST. PETERSBURG, FL 33714

P: 727-572-0061
TOLL FREE: 800-842-4164
WWW.CONTINENTALTRAILERS.COM